



Mt. Prospect Park District

Serving Portions of Mt. Prospect • Des Plaines • Arlington Heights • Elk Grove Village

www.mppd.org

ADMINISTRATIVE OFFICES

(847)255-5380
Fax (847)255-1438
1000 W. Central Road
Mt. Prospect, IL 60056

CENTRAL COMMUNITY CENTER

(847)255-5380
Fax (847)392-5726
1000 W. Central Road
Mt. Prospect, IL 60056

RECPLX

(847)640-1000
Fax (847)364-2824
420 W. Dempster Street
Mt. Prospect, IL 60056

LIONS

RECREATION CENTER

(847)632-9333
Fax (847)632-9325
411 S. Maple Street
Mt. Prospect, IL 60056

FRIENDSHIP PARK

CONSERVATORY

(847)298-3500
Fax (847)296-2053
395 Algonquin Road
Des Plaines, IL 60018

MT. PROSPECT GOLF CLUB

(847)259-4200
Fax (847)632-9334
600 See-Gwun
Mt. Prospect, IL 60056

GOLF MAINTENANCE

(847)632-9330
Fax (847)342-9113
600 See-Gwun
Mt. Prospect, IL 60056

MAINTENANCE FACILITY

(847)956-6773
Fax (847)956-6911
1645 Carboy
Mt. Prospect, IL 60056

November 13, 2015

Tracy Crawford
Executive Director
Northwest Special Recreation Association
3000 Central Road – Suite 205
Rolling Meadows, IL 60008

Re: ADA Improvements – Melas Park / Central Rd. Crossing Improvements
Ms. Crawford,

The Mt. Prospect Park District hereby notifies and requests approval of the NWSRA Board of Directors for the proposed expenditures of funds from the Park District's Special Recreation levy to pay for the following improvements:

Reimbursement for ADA related improvements which will provide for a safe ADA accessible route of travel from Weller Lane across Central Road to Melas Park. This new route will provide ADA access to and from the Melas Park Path System and Melas Athletic Fields.

These improvements will provide new ADA accessible sidewalks, curb ramps, traffic control devices and signage as well as a median refuge area. The total ADA Related costs for the Park Districts share of this project is \$36,615.88. The total cost the park district wishes to seek reimbursement for is \$ 11,709.31. A full outline of this project is attached to this request for your review.

The Mt. Prospect Park District respectfully requests that you consider this proposal and present it with your favorable recommendation to the NWSRA Board of Directors. If you have questions or require additional information please do not hesitate to contact me at (847) 255-5380.

Sincerely,

Jim Jarog
Director of Parks & Planning
Mt. Prospect Park District

CC: Greg Kuhs
Executive Director
Mt. Prospect Park District

**Central-Weller Crossing Improvements
Village of Mount Prospect
Cost Breakdown**

Total Construction Cost*	\$164,621.86	a	
Village Share**	\$128,005.98	a	77.8%
Park District Share***	\$36,615.88	a	22.2%
Construction Engineering (Inspection) Cost*	\$19,508.24	b	
Village Share (77.8%)	\$15,177.41	b	
Park District Share (22.2%)	\$4,330.83	b	
Construction + Inspection Cost	\$184,130.10	a + b	
Total Village Cost	\$143,183.39	a + b	
Total Park District Cost	\$40,946.71	a + b	
Safe Routes To School Grant	\$131,700.00	c	
Village Share (77.8%)	\$102,462.60	c	
Park District Share (22.2%)	\$29,237.40	c	
Remaining Cost Not Paid By Grant	\$52,430.10	(a + b) - c	
Village Share (77.8%)	\$40,720.79	(a + b) - c	
Park District Share (22.2%)	\$11,709.31	(a + b) - c	

* actual contract award

** based on work within IDOT & Village rights-of-way

*** based on work on Park District property

Central Road and Weller Lane Pedestrian Improvement

ITEM #	DESCRIPTION	UNIT	UNIT COST	TOTAL	TOTAL COST	PARK DISTRICT	PARK DISTRICT \$
20101000	Temporary Fence	FOOT	\$2.00	570	\$1,140.00	570	\$1,140.00
20101200	TREE ROOT PRUNING	EACH	\$200.00	5	\$1,000.00	5	\$1,000.00
20200100	EARTH EXCAVATION	CU YD	\$18.75	34	\$637.50	10	\$187.50
20400800	FURNISHED EXCAVATION	CU YD	\$1.00	207	\$207.00	174	\$174.00
28000500	INLET AND PIPE PROTECTION	EACH	\$150.00	1	\$150.00	1	\$150.00
28000510	INLET FILTERS	EACH	\$150.00	2	\$300.00	0	\$0.00
21101505	TOPSOIL EXCAVATION AND PLACEMENT	CU YD	\$90.00	53	\$4,770.00	53	\$4,770.00
21101625	TOPSOIL FURNISH AND PLACE, 6"	SQ YD	\$9.70	474	\$4,597.80	306	\$2,968.20
21400100	GRADING AND SHAPING DITCHES	FOOT	\$10.00	75	\$750.00	75	\$750.00
25000400	NITROGEN FERTILIZER NUTRIENT	POUND	\$3.00	9	\$27.00	5	\$15.00
25000500	PHOSPHORUS FERTILIZER NUTRIENT	POUND	\$3.00	9	\$27.00	5	\$15.00
25000600	POTASSIUM FERTILIZER NUTRIENT	POUND	\$3.00	9	\$27.00	5	\$15.00
25200110	SODDING, SALT TOLERANT	SQ YD	\$6.50	1050	\$6,825.00	625	\$4,062.50
25200200	SUPPLEMENTAL WATERING	UNIT	\$0.01	48	\$0.48	29	\$0.29
35301400	AGGREGATE BASE COURSE, TYPE B	TON	\$20.00	136	\$2,720.00	74	\$1,480.00
40603335	HOT-MIX ASPHALT SURFACE COURSE, MIX "D", N50	TON	\$167.83	56	\$9,388.48	33	\$5,538.39
42400200	PORTLAND CEMENT CONCRETE SIDEWALK 5 INCH	SQ FT	\$7.00	1579	\$11,053.00	0	\$0.00
42400800	DETECTABLE WARNINGS	SQ FT	\$25.00	122	\$3,050.00	0	\$0.00
44000100	PAVEMENT REMOVAL	SQ YD	\$42.00	314	\$13,188.00	145	\$6,090.00
44000500	COMBINATION CURB AND GUTTER REMOVAL	FOOT	\$15.00	240	\$3,600.00	0	\$0.00
44000600	SIDEWALK REMOVAL	SQ FT	\$5.00	1681	\$8,405.00	0	\$0.00
50105220	PIPE CULVERT REMOVAL	FOOT	\$1.00	60	\$60.00	60	\$60.00
54214509	PRECAST REINFORCED CONCRETE FLARED END SECTIONS, EQUIVALENT ROUND-SIZE 24"	EACH	\$3,000.00	2	\$2,000.00	2	\$2,000.00
5425479	PIPE CULVERTS, CLASS A, TYPE 1 EQUIVALENT ROUND-SIZE 24"	FOOT	\$100.00	62	\$6,200.00	62	\$6,200.00
55100700	STORM SEWER REMOVAL, 15"	FOOT	\$10.00	5	\$50.00	0	\$0.00
60237470	INLETS, TYPE A, TYPE 24 FRAME AND GRATE	EACH	\$650.00	1	\$650.00	0	\$0.00
60255500	MANHOLES TO BE ADJUSTED	EACH	\$300.00	1	\$300.00	0	\$0.00
60260100	INLETS TO BE ADJUSTED	EACH	\$300.00	1	\$300.00	0	\$0.00
60500050	REMOVING CATCH BASINS	EACH	\$283.00	1	\$283.00	0	\$0.00
60605000	COMBINATION CONCRETE CURB AND GUTTER, TYPE B-6-24	FOOT	\$40.00	209	\$8,360.00	0	\$0.00
60608562	COMBINATION CONCRETE CURB AND GUTTER, TYPE M-4-12	FOOT	\$30.00	33	\$990.00	0	\$0.00
60619600	CONCRETE MEDIAN, TYPE SR-6-12	SQ FT	\$17.70	834	\$14,761.80	0	\$0.00
67100100	MOBILIZATION	L SUM	\$20,000.00	1	\$20,000.00	0	\$0.00
70102632	TRAFFIC CONTROL AND PROTECTION, STANDARD 701602	L SUM	\$1.00	1	\$1.00	0	\$0.00
70102635	TRAFFIC CONTROL AND PROTECTION, STANDARD 701701	L SUM	\$1.00	1	\$1.00	0	\$0.00
70102640	TRAFFIC CONTROL AND PROTECTION, STANDARD 701801	L SUM	\$4,900.00	1	\$4,900.00	0	\$0.00
70103815	TRAFFIC CONTROL SURVEILLANCE	CAL DA	\$1.00	10	\$10.00	0	\$0.00
72000100	SIGN PANEL - TYPE 1	SQ FT	\$30.00	70	\$2,100.00	0	\$0.00
72000200	SIGN PANEL - TYPE 2	SQ FT	\$40.00	25	\$1,000.00	0	\$0.00
72400100	REMOVE SIGN PANEL ASSEMBLY - TYPE A	EACH	\$40.00	6	\$240.00	0	\$0.00
72400310	REMOVE SIGN PANEL - TYPE A	SQ FT	\$9.00	18	\$162.00	0	\$0.00
72800100	TELESCOPING STEEL SIGN SUPPORT	FOOT	\$15.00	23	\$345.00	0	\$0.00
72900100	METAL POST - TYPE A	FOOT	\$10.00	33	\$330.00	0	\$0.00
73100100	BASE FOR TELESCOPING STEEL SIGN SUPPORT	EACH	\$60.00	2	\$120.00	0	\$0.00
78000200	THERMOPLASTIC PAVEMENT MARKING - LINE 4"	FOOT	\$2.00	737	\$1,474.00	0	\$0.00
78000400	THERMOPLASTIC PAVEMENT MARKING - LINE 6"	FOOT	\$3.00	94	\$282.00	0	\$0.00
78000600	THERMOPLASTIC PAVEMENT MARKING - LINE 12"	FOOT	\$6.00	383	\$2,298.00	0	\$0.00
78300100	PAVEMENT MARKING REMOVAL	SQ FT	\$0.90	572	\$514.80	0	\$0.00
87800100	CONCRETE FOUNDATION, TYPE A	FOOT	\$420.00	6	\$2,520.00	0	\$0.00
A2004720	TREE, GLEITSIA TRICANTHOS INERMIS SHADENMASTER (SHADENMASTER THORNLESS COMMON HONEYLOCUST), 2-1/2" CALIPER, BALLED AND BURLAPPED	EACH	\$798.00	2	\$1,596.00	0	\$0.00
A2005040	TREE, GYMNOCLADUS DIOCLUS ESPRESSO-JFS ESPRESSO KENTUCKY COFFEE TREE, 2-1/2" CALIPER, BALLED AND BURLAPPED	EACH	\$798.00	1	\$798.00	0	\$0.00
Z0001110	GAS VALVE TO BE ADJUSTED	EACH	\$250.00	1	\$250.00	0	\$0.00
Z0013798	CONSTRUCTION LAYOUT	L SUM	\$2,270.00	1	\$2,270.00	0	\$0.00
Z0030850	TEMPORARY INFORMATION SIGNING	SQ FT	\$16.00	52	\$832.00	0	\$0.00
Z0007021	PEDESTRIAN ACTIVATED CROSSWALK WARNING SYSTEM	EACH	\$16,700.00	1	\$16,700.00	0	\$0.00
					\$154,621.86	TOTAL	\$36,615.88



Illinois Safe Routes to School Funding Application
2013-2014 Funding Cycle

Infrastructure Project Application

Funding for projects under these application criteria may be used to plan, design, and construct infrastructure related projects that will substantially improve the ability of students (grades K – 8) to walk and bike to school.

Application Name: Central Rd - Weller Ln Pedestrian Crossing Improvement Project.

Application Sponsor (Primary Contact)

Entity*: Local Government Regional Transportation Authority
School District, Local Education Agency, or School

<p>Applicant: Name: Village of Mount Prospect Title: Mailing Address: 50 S. Emerson Street City: Mount Prospect County: Cook Zip: 60056 Phone: 847-392-6000 Fax: Email:</p>	<p>Project Manager &/or Sponsor: Matthew Lawrie Traffic Engineer 1700 W. Central Road Mount Prospect Cook 60056 847-870-5640 847-253-9377 mlawrie@mountprospect.org</p>
--	---

**Nonprofit organizations and Metropolitan Planning Organizations are not eligible for SRTS funds per MAP 21 guidelines.*

<p>Is applicant agency within an MPO? <input checked="" type="checkbox"/> Yes <input type="checkbox"/> No (If yes, provide contact info and include letter of project concurrence.)</p>		<p>MPO: CMAP/NWMC</p>
<p>Name: Mike Walczak</p>	<p>Phone: 847-296-9200</p>	
<p>Address: 1600 E. Golf Road #0700</p>	<p>Fax: 847-296-9207</p>	
<p>City/Zip: Des Plaines/60016</p>	<p>Email: mwalczak@nwmc-cog.org</p>	

<p>Project Cost:</p>	
<p>Total: \$134,400.00</p>	<p>Requested Amount: \$115,500.00 (\$200,000.00 maximum)</p>
<p>80% SRTS Funding: \$92,400.00 (maximum \$160,000.00)</p>	
<p>20% Local Match: \$23,100.00 (maximum \$40,000.00) local funds will cover all costs above SRTS funding</p>	

Contingencies: Is this project contingent on the completion of another project? Yes No If yes, name of project(s):

School Proximity: Is this project located within 2 miles of a primary or middle school (grades K-8)? Yes No



**Illinois Safe Routes to School Funding Application
2013-2014 Funding Cycle**

Infrastructure Project Application

Public Input Process

- Parent Surveys and Student Tallies Yes No (Attach files associated to this project)
- Interview Key Stakeholders (optional) Yes No (Attach written interviews) same as Parent Survey
- Public Comment Period** Yes No Dates 08/10 to 11/10 (attach sample comments)
- Engineering Studies Yes No (Attach documentation) ** part of Bike Plan development
- Conduct Community "Walkabout" Yes No Date: 06/09/12 (Attach photos) performed by CMAP
Location:
Description:
- Conduct Community "Bikeabout" Yes No Date: (Attach photos)
Location:
Description:
- Incorporate School Wellness Policy Yes No (Attach written policy)

Project Categories: Infrastructure

1. Sidewalks*	<input checked="" type="checkbox"/>	4. Traffic Diversion	<input type="checkbox"/>
New Sidewalk	<input type="checkbox"/>	Separation of Bicycles and pedestrians from traffic adjacent to school facilities	<input type="checkbox"/>
Sidewalk Repair	<input type="checkbox"/>	Traffic diversion away from school zone or designated route to school	<input type="checkbox"/>
Sidewalk Gap Closure	<input type="checkbox"/>	New/Revised Pick-up/Drop-off Zone	<input type="checkbox"/>
Sidewalk Widening	<input type="checkbox"/>		
Sidewalk Curb	<input type="checkbox"/>		
Sidewalk Curb Ramp	<input checked="" type="checkbox"/>		
2. Traffic Calming/Speed Reduction	<input type="checkbox"/>	5. Pedestrian and Bicycle Crossing Improvements	<input checked="" type="checkbox"/>
Bulb-out	<input type="checkbox"/>	Crossing	<input checked="" type="checkbox"/>
Speed Bump/Hump/Table	<input type="checkbox"/>	New/Upgraded Signs	<input checked="" type="checkbox"/>
Raised Crossing	<input type="checkbox"/>	Median Refuge	<input checked="" type="checkbox"/>
Median Refuge/Center Crossing	<input type="checkbox"/>	Raised Crossing	<input type="checkbox"/>
Narrowed Traffic Lane	<input type="checkbox"/>	Sight Distance Improvements	<input checked="" type="checkbox"/>
Chicane	<input type="checkbox"/>		
Choker	<input type="checkbox"/>	6. On Street Bicycle Facilities	<input type="checkbox"/>
Lane Reductions	<input type="checkbox"/>	New/Upgraded Bike Lane	<input type="checkbox"/>
Full/Half Street Closure	<input type="checkbox"/>	Widened Outside Lanes/Shoulders	<input type="checkbox"/>
3. Traffic Control Devices	<input checked="" type="checkbox"/>	Geometric Improvements	<input type="checkbox"/>
New/Upgraded Signs	<input type="checkbox"/>	Channelization	<input type="checkbox"/>
New/Upgraded Traffic Signals	<input type="checkbox"/>	Traffic Signs	<input type="checkbox"/>
New Pavement Markings	<input type="checkbox"/>	Pavement Markings	<input type="checkbox"/>
New Traffic Striping	<input type="checkbox"/>		
In-Roadway Crossing Light	<input type="checkbox"/>	7. Off Street Bicycle and Pedestrian Facilities	<input checked="" type="checkbox"/>
Flashing Beacons	<input checked="" type="checkbox"/>		
Bike Sensitive Signal Actuation Device	<input type="checkbox"/>	8. Secure Bicycle Parking Facilities	<input type="checkbox"/>
Pedestrian Activated Signal Upgrades	<input type="checkbox"/>	Bike Racks	<input type="checkbox"/>
Pedestrian Countdown Signals	<input type="checkbox"/>	Bike Lockers	<input type="checkbox"/>
Vehicle Speed Feedback Signs	<input type="checkbox"/>	Designated Area with Safety Lighting	<input type="checkbox"/>
		Covered Bike Shelters	<input type="checkbox"/>

*All sidewalk improvements will be required to meet ADA requirements.



**Illinois Safe Routes to School Funding Application
2013-2014 Funding Cycle**

Infrastructure Project Application

Improvements Mapping:

(Attach or upload maps for school(s) in the plan and proposed improvement location(s).)

Infrastructure Project Details

Infrastructure Project Description: (Detailed summary of project)

<p>Description of Project: Central Road is an arterial roadway with a 35 mph speed limit and carries over 21,000 vehicles per day. At its intersection with Weller Lane, a regional destination facility, Melas Park, is on the north side of the street. A neighborhood that includes Westbrook School and Lincoln Junior High School is on the south side of the street. The existing crosswalk is approximately 70' long and has only painted markings and signs. Enhancements to the crossing will include a refuge island, a rectangular rapid flashing beacon system, ADA ramps, new signs, and new pavement markings. The crossing distance will be shortened to enhance pedestrian safety and improve the sight distance of the signs and beacons. The bike path on the north side will be realigned and an off-street bike path will replace the sidewalk on the south side and connect to the school.</p>	
<p>Project School (school name, city, county & description): Westbrook School and Lincoln Junior High School Mount Prospect, Cook County Westbrook School serves pre-K, K & 1st grade students. Lincoln Junior High serves 7th and 8th grade students.</p>	
<p>Demonstration of Need: Parents, teachers and administration of School District 57 identified this crossing as a barrier to walking and biking in their recent School Travel Plan. To many students walking or biking are not options because of the crossing's current conditions. An improved crossing will benefit students as well as all users throughout the year because of the crossing's close proximity to Melas Park.</p>	
<p>School Demographics*:</p>	<p>Physical Environment: (<i>urban, rural, suburban, etc.</i>) suburban</p>
	<p>Total # students: Westbrook-515/Lincoln-680 households:</p>
	<p>% students designated as low income: Westbrook-6/Lincoln-6</p>
	<p>Total # Disabled students: Westbrook-5/Lincoln-10</p>
<p>Safety Hazards and Barriers to Walking and Bicycling: Many parents have identified this crossing as unsafe for students because of its long crossing with minimal safety elements. Motorists rarely yield the right-of-way to students making crossing the street difficult. As a result, parents drive their children to school rather than walking or biking.</p>	
<p>Potential to Reduce Child Injuries and Fatalities: (document any related traffic crashes or number of citations issued) Motorists rarely yield the right-of-way to walkers and bicyclists at this crossing. This, along with the long crossing distance without a refuge island, makes it difficult for students to find a sufficient gap to cross the street. This project will reduce the time students are in the roadway and compel motorists to stop.</p>	
<p>Creating Solutions (Strategies including the Encouragement, Engineering, Enforcement, Education and Evaluation – the 5 E's): The Engineering part of this project will create an environment that is safer for students to walk and bike to school. The school district has and will continue to promote walking and biking to schools. Teaching bike skills and providing a walking school bus program are a couple of Education and Encouragement strategies ongoing by the schools. The Police Department plays an active role in Enforcing traffic laws for both motorists and students, and will be integral in the success of this project. Parent surveys and field counts have been conducted and will be done again after completion of the project as part of the Evaluation process.</p>	
<p>Potential for Improving Walking & Bicycling: Based on ongoing programs created by the school district, there is an eagerness for parents to want their children to walk and bike to school. There are over 500 households on the north side of Central Road that would benefit from an improved crossing resulting in many more students walking and biking to school. The improved crossing would also benefit users of Melas Park throughout the year.</p>	



**Illinois Safe Routes to School Funding Application
2013-2014 Funding Cycle**

Infrastructure Project Application

Consultation and Support: A School Travel Plan was finalized for School District 57 in 2012. Team members included administration, teachers, parents, the Village of Mount Prospect, and the Active Transportation Alliance. This project includes Letters of Support from School District 57, Mount Prospect Park District, Active Transportation Alliance, and the Northwest Municipal Conference. Engineering plans have also been reviewed and supported by the Illinois Department of Transportation.

Travel Information-Current (Number of Children)
Westbrook / Lincoln

	Walk	Bike	School Bus	Car-rider	Public Transit	Other
#	20/68	0/7	149/211	346/394	0/0	0/0
%	4/10	0/1	29/31	67/58	0/0	0/0

	Less Than One Mile	One to One Half Mile	More than One Half Mile (car/bus riders)
#	67/150	77/150	371/380
%	13/22	15/22	72/56

Travel Information-Proposed (Number of Children)
Westbrook / Lincoln

	Walk	Bike	School Bus	Car-rider	Public Transit	Other
#	31/82	15/27	149/211	320/360	0/0	0/0
%	6/12	3/4	29/31	62/53	0/0	0/0

	Less Than One Mile	One to One Half Mile	More than One Half Mile (car/bus riders)
#	67/150	77/150	371/380
%	13/22	15/22	76/56

Community Support: The crossing at Central Road and Weller Lane has been identified as a barrier to walking and biking by parents, administration, teachers, the School Board and the Village in the School Travel Plan. Improvements at this crossing are still supported by these stakeholders. Further, the Village Bicycle Plan identifies this crossing to be improved and continues to be supported by residents. The Mount Prospect Park District, a key stakeholder with managing Melas Park, also supports the project.

Infrastructure Project Cost Details

Construction Project Category	Cost (attach detailed estimate)	
Cost Type	Amount	Description
Equipment	\$0.00	
Material	\$105,000.00	construction items detailed in attached cost estimate
Consultant Services (maximum 10%)	\$10,500.00	services to assist with plan development & construction inspection
Right of Way	\$0.00	
Total	\$115,500.00	



**Illinois Safe Routes to School Funding Application
2013-2014 Funding Cycle**

Infrastructure Project Application

Summary:

The Village of Mount Prospect, with the cooperation and support of School District 57 and the Mount Prospect Park District, is prepared to improve the pedestrian crossing at Central Road and Weller Lane. The addition of a rectangular rapid flashing beacon system, refuge island, signs, pavement markings and an off-street path will make the area safer for students walking and biking to Westbrook School and Lincoln Junior High School. The improvements will reduce the crossing distance and provide a safe refuge for students. The flashing beacons and signs will compel motorists to yield the right-of-way to students. The improvements will not only enhance safety for students but also encourage more walkers and bikers in the community.

The School Travel Plan and Village Bicycle Plan both recommend improvements at this crossing. With only pavement markings and signs, the 70' crossing can be difficult for any pedestrian or bicyclist, especially students. In 2013 the Village showed a commitment to improve the crossing. A consultant was retained to develop engineering drawings (attached). Multiple meetings took place with the Illinois Department of Transportation (IDOT) and the park district to determine an acceptable solution. The Village continues to be in communication with IDOT.

In addition to the engineering component to see more students walking and biking to school safely, we are committed to the other four E's. The school district will continue to encourage and educate students on the benefits of walking and biking. The Police Department will continue to provide enforcement and education to assure motorists and students are behaving responsibly. And the Village and school district will evaluate the success of our efforts and continue to look for other opportunities to see more students walking and biking to school.

The project is supported by many stakeholders including parents, administration, and teachers of School District 57, the Mount Prospect Park District, and the Village. It is also supported by the Active Transportation Alliance and the Northwest Municipal Conference. Our efforts thus far in creating a School Travel Plan, evaluating the crossing, and developing engineering drawings shows our commitment to see this project through to completion. With this improvement, we fully expect to see safety enhanced at the crossing and more walkers/bicyclists to our schools and the park.

Other Supporting/Coordination Documentation (Attach all supporting documentation for this application)

Partnerships/coordination between schools and local government
Endorsement representatives

Evaluations: (How will success be measured?)

Will conduct and provide new student counts & tallies within 6 months of close of project

Agree Disagree

Will conduct and provide parent surveys within 6 months of close of project

Agree Disagree

Additional SRTS Team Members:

Name: Dale Falk, CCSD 57

Email: dfalk@d57.org

Phone: 847-394-7300

Name: Randy Steen, CCSD 57

Email: rsteen@d57.org

Phone: 847-394-7350

Name: Mary Gorr, CCSD 57

Email: mgorr@d57.org

Phone: 847-394-7340

Name: Jim Jarog, MP Park District

Email: jjarog@mppd.org

Phone: 847-255-5380

Name: Nellie Beckner, Village

Email: nbeckner@mountprospect.org

Phone: 847-818-5328

Name:

Email:

Phone:



Illinois Safe Routes to School Funding Application
2013-2014 Funding Cycle

Infrastructure Project Application

Options for submittal:

Mail supporting documentation along with completed application to the following address:

Illinois Department of Transportation
Bureau of Safety Engineering-Safe Routes to School
2300 S. Dirksen Parkway, Room 323
Springfield, IL 62764

Scan and email all documentation along with completed application to the following email address:

DOT.SAFEROUTES@illinois.gov.

Upload all documentation along with completed application.

*All schools must be registered with the Illinois State Board of Education (ISBE) to be eligible for Safe Routes to School funding.



November 12, 2015

Tracey Crawford
 Executive Director
 Northwest Special Recreation Association
 3000 Central Road- Suite 205
 Rolling Meadows, IL 60008

Elk Grove Park District
 Board of Commissioners

Bob Biedke

Tom Cooke

Bill O'Malley

Ralph Souder

John Walz

Thomas A. Busby
 Executive Director

RE: 2015 Elk Grove Park District Projects to be Financed Using Special Recreation Levy

Dear Ms. Crawford,

The Elk Grove Park District hereby notifies and requests approval of the NWSRA Board of Directors for the expenditure of funds from the District's special recreation levy, to pay the cost of the following improvements.

Project	Project Total	ADA Expenditures
Audubon Playground Renovation	\$90,000	\$ 27,000.00
Rainbow Falls Leisure Pool Lift and installation	\$6,550	\$ 6,550.00
Johnson Pond Accessible Fishing Pier *	\$21,000	\$ 11,660
Accessible route repairs and replacements Mead Park	\$10,500	\$7,600
Fox Run Golf Club and Rainbow Falls ADA signage	\$	\$218.88
Replacement adaptive swings Lindbergh Park	\$1,500	\$1,446.00
Total		\$54,474.88

*Fishing pier concrete base installed, pier and railings to be installed spring 2016. Project delayed due to permit issues.

The costs of improvements are **\$54,474.88**. The improvements will be completed by December 30, 2015. Anticipated benefits of the project to NWSRA are as follows:

Audubon Park \$27,000 This playground renovation included playground equipment that has transfer platforms to access the play equipment, a supportive multi-user swing, two adaptive swings and an accessible seat for the zip line. The engineered wood fiber play surface provides access to the play equipment. New concrete walks provide an accessible route to the playground and equipment.

Elk Grove Park District
 499 Biesterfield Road
 Elk Grove Village, IL
 60007

Phone: 847-690-1190
 Fax: 847-228-3508
 www.elkgroveparks.org

Rainbow Falls Leisure Pool Lift \$6,550 The existing leisure pool lift was no longer functioning properly and was replaced. The equipment was installed prior to the opening of the pool for the 2015 season.

Johnson Park Pond Accessible Fishing Pier \$11,660 The Park District did not have any accessible fishing within the district. A review of two potential sites, Salt Creek and a one acre pond at Johnson Park showed the latter to be a better location. The Village required permits for the pier and access that delayed the project. A concrete access ramp and walk bring users to the pier. The concrete abutment was installed in November. Fish were stocked in the spring of 2015 in anticipation of a fishing derby to highlight this new recreational opportunity for the community. The actual pier shall be installed in spring 2016 at an additional \$10,880.

Accessible Route Repairs & Replacement Mead \$7,600 The accessible route to the two softball fields at Mead had several areas of concrete that had shifted forming trip hazards and standing water. The best solution was to replace the concrete and provide smooth transitions to all spectator areas and the restrooms.

Fox Run Golf Club and Rainbow Falls ADA parking signs \$218.88 The parking lots were seal coated and re-stripped during the year. The old signs had faded and needed replacing. The sign heights were not compliant at the golf club and shrubs had grown over the lower level of the signs. Guests arriving for golf, meetings and functions can easily access the clubhouse. Rainbow Falls parking lot was also seal coated and striped and new signs installed to replace those missing or faded.

Lindbergh Park Replacement ADA swings \$1,446.00 The existing supportive swings were damaged and new swings were needed to support the usage at this joint park/school site. The new adaptive swings have a better closure mechanism that is sturdier and should hold up much better.

The Elk Grove Park District respectfully requests that you review this request for fifty-three thousand, nine hundred seventy-nine dollars and eighty-eight cents (\$54,474.88) and present it with your approving recommendation to the NWSRA Board of Directors. If you have any questions or require additional information, please do not hesitate to contact me.

Sincerely,

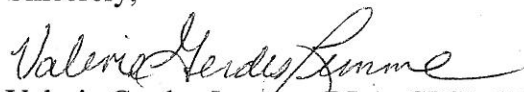

Valerie Gerdes Lemme, RLA, CPSI, CPRP
Planner II

CC: Tom Busby
Ben Curcio



November 20, 2015

Tracey Crawford
Executive Director
Northwest Special Recreation Association
3000 Central Road- Suite 205
Rolling Meadows, IL 60008

Elk Grove Park District
Board of Commissioners

Bob Biedke

Tom Cooke

Bill O'Malley

Ralph Souder

John Walz

Thomas A. Busby
Executive Director

RE: 2015 Elk Grove Park District Projects to be Financed Using Special
Recreation Levy- Additional Documentation

Dear Ms. Crawford,

The attached supportive documents are for the expenditures for 2015.

Audubon Park Playground Renovation: new accessible route and ramp into
playground, new equipment with supportive seating for side by side play, a group
swing, and new 2-5 year old composite play structure with a transfer station.
Accessible benches were included in the restoration.

Play equipment from Landscape Structures	\$9,000
Play equipment from Gametime (2-5 year old composite unit)	\$9,000
Concrete walk/accessible route and ramp	<u>\$9,000</u>
	\$27,000

Rainbow Falls Leisure Pool Lift replacement Pro Pool-XR lift	\$4,562.98
Installation	<u>\$1,987.02</u>
	\$6,550.00

Johnson Park Pond Fishing Pier Concrete work completed Nov. 2015	\$11,600
Contractor: E. Hoffman Inc. Pier installation to be completed 2016 (\$10,880)	

Mead Accessible route repairs	\$7,600
Contractor: E. Hoffman Inc.	

Fox Run Golf Club and Rainbow Falls ADA parking signs	\$ 129.28
	<u>\$ 86.60</u>
Contractor: Divine Signs	\$ 218.88

Lindbergh Park Replacement ADA Swings	\$1446.00
Landscape Structures-NuToys Leisure Products Installed by staff	

See attached pages for additional information.

Sincerely,

Valerie Gerdes Lemme
Valerie Gerdes Lemme, RLA, CPSI, CPRP

Elk Grove Park District
499 Biesterfield Road
Elk Grove Village, IL
60007

Phone: 847-690-1190
Fax: 847-228-3508
www.elkgrovetparks.org

Aqua Creek Products
The Total Solution for Pool and Spa Access

Pro Pool-XR Lift

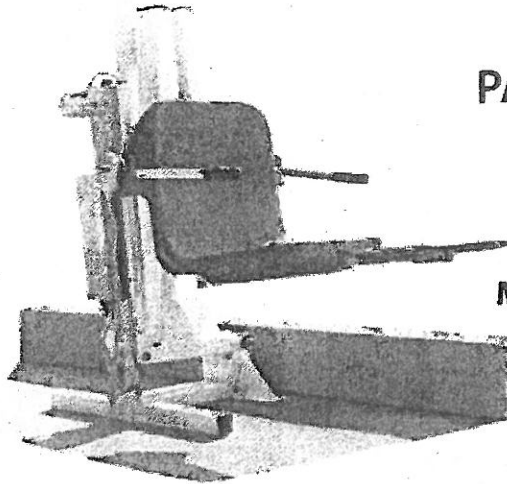

PART #: F-004PLB-XR (with anchor)
PART #: F-004PLB-XRNA (without anchor)

US PATENT NUMBER: [D507,769 S] [7,249,386 B2]
350 LB. [159 kg] MAXIMUM WEIGHT CAPACITY

MANDATORY – LEAVE THIS MANUAL WITH LIFT OWNER



Read & follow all instructions
Lift safety can only be ensured if the lift is installed and operated according to these instructions

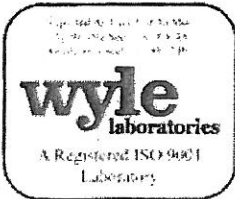

NEVER permit children to play on or around the lift
Do not allow children to use the lift without adult supervision



NEVER apply direct water pressure to the electronics

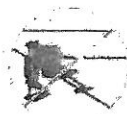

NEVER use the lift with a dry pool



For safety reasons, NEVER swim alone

9889 Garrymore Ln
Missoula, MT 59808
888-687-3552 | +1-406-549-0769
aquacreek.com



SAVE a copy of these instructions



320 Industrial Dr.
West Chicago, Illinois 60185
Customer Service (800) 374-1500
www.intheswim.com

INVOICE NUMBER: 4929893
PICK: 01004929893.01
INVOICE DATE: 02/20/15

BATCH: 1100414
WHSE#: 0100

ORDER NO./DATE: 15190829 02/17/15

*GRP:905 *
*NO SHIP *

CUSTOMER NUMBER: 962054
ORDER SOURCE: CVCZRUNK

PAGE: 1
DIVISION: C

BILL TO:
C#000962054 P#847-690-1109
ATTN: JOHN
ELK GROVE PARK DISTRICT
499 BIESTER FIELD RD
ATTEN: JIM C/LORI P
ELK GROVE VILLAGE IL 60007

SHIP TO:
C#000962054 P#847-690-1109
ATTN: JOHN
ELK GROVE PARK DISTRICT
200 REV. MORRISON
ATTEN: JOHN
ELK GROVE VILLAGE IL 60007

PRICE: 1 TOTAL WEIGHT: 0.00 ITEMS TO SHIP: 0

PURCHASE ORDER NO. 56684

*MASTERCARD *

SHIPPING INFORMATION: FedEx Ground

SALESPERSON: 532/STAN E (AM)

ORD	SHIP	PRODUCT NUMBER / DESCRIPTION	PRICE	EXTENSION	LOC.
1		D P0002 / AQUA CREEK LIFT SPECIAL ORD PART #, DESC. AND ITS #???	4128.00	4128.00	
		Lift, Pro Pool XR, with Anchor			
		PART# F-004PLB-XR			
		ITS# 00-5992			
		AQUA CREEK			
1		D P6982 / LIFT COVER	204.99	204.99	
1		D P7042 / REPLACEMENT BATTERY 24V	229.99	229.99	

GL# _____
Description _____

FEB 28 2015

STATUS CODES: S - SHIPPED FROM OTHER LOCATION B - ITEM BACKORDERED C - ITEM CANCELLED D - NO LONGER AVAILABLE * - SPECIAL PRICED D- ITEM DROP SHIPPED

ALL ITEMS SHIP FEDEX. IF OVER 500LBS TRUCK

NET CHARGES: 4562.98
TOTAL: 4562.98
CHRG CARD 4562.98

Approval _____
P.O. # _____

YOUR ORDER MAY BE SHIPPED FROM MULTIPLE LOCATIONS. PLEASE ALLOW 5 DAYS TO RECEIVE YOUR COMPLETE ORDER.



FedEx Ground
PKG# 1-004929893-0102



FedEx Ground
PKG# 1-004929893-0101



320 Industrial Dr.
West Chicago, Illinois 60185
Customer Service (800) 374-1500
www.intheswim.com



320 Industrial Dr.
West Chicago, Illinois 60185
Customer Service (800) 374-1500
www.intheswim.com

200 REV. MORRISON
ATTEN: JOHN
ELK GROVE VILLAGE IL 60007

200 REV. MORRISON
ATTEN: JOHN
ELK GROVE VILLAGE IL 60007

**SATISFACTION
GUARANTEED**

WE VALUE YOU AS A CUSTOMER AND WANT YOU TO BE SATISFIED WITH ALL OF YOUR **IN THE SWIM**® SUPPLIES

TO RETURN MERCHANDISE, PLEASE FOLLOW THESE INSTRUCTIONS!

RETURN POLICY:

If you are not fully satisfied with any In The Swim® product, return it within 14 days for a full product refund. Returns received 15-30 days after the date of purchase are subject to a 20% restocking fee. Due to the nature of the product, no returns will be accepted on custom orders (except for manufacturer defects), above-ground liners and drilled solar reels. Handling fees are non-refundable.

COMPLETE THE FORM below and include it with the returned item(s). Please make sure to indicate the reason for return below. If you received a damaged or incorrect product, please call Customer Care at 1-800-374-1500. The appropriate credit or refund will be issued when your return is processed.

SEND YOUR PACKAGE to us prepaid via Fed Ex, UPS or U.S. Mail. Charges for shipping returned products back to us are your responsibility. No C.O.D. or collect shipments will be accepted. Insure the package for its full value. Keep your shipping receipts until you have received credit for your return. **IN THE SWIM**® is not responsible for returned items lost in shipping.

SHIP YOUR PACKAGE TO: Attn: Returns
In The Swim
320 Industrial Dr.
West Chicago, IL 60185

QUESTIONS? Please call Customer Care 1-800-374-1500.

THERE IS NO NEED TO CALL FIRST.

RETURNED ITEMS

ITEM #	DESCRIPTION	QTY	PRICE	RETURN CODE

Please explain reason: _____

Return Codes: Please indicate your reason for return using the following codes in the column labeled **RETURN CODE** under Returned Items.

RD- defective product (please explain)
RE- not what expected (please explain)

RK- shipped wrong product
RS- damaged in shipping

OTHER-(please explain)
WARR- warranty replacement

ITEMS WANTED IN EXCHANGE

ITEM #	DESCRIPTION	QTY	PRICE

Dear Valued Customer,
Customer satisfaction is our ultimate goal at In the Swim®. A crucial step in achieving this goal is through your feedback. If you are dissatisfied for any reason with a product or service we offer, we want to know about it so we can correct the situation as soon as possible. At In The Swim®, we value your feedback as a major contribution to our organization and look forward to a long and prosperous relationship with all of our customers.

from the Staff at In The Swim®

Thank you!

**Remember to visit us on
the web at**

www.InTheSwim.com

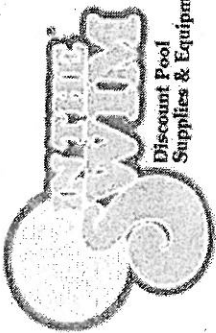

320 Industrial Drive
West Chicago, IL 60185

Phone: 1-888-859-6951x 6318
Email: sellison@inthewim.com

Fax: 1-800-448-7329

10336

Quotation

To: ELK GROVE PARK DISTRICT
499 BIESTER FIELD RD
ELK GROVE VILLAGE, IL 60007

Attn: John Walters

Quotation #: 962054 - 02122015 - 1
Date: 2/17/2015
Customer ID: 962054
Fax #:
Phone: 1-847-593-6248

Item #:	E-SPEC	Quantity	Description	Discount Price	Total Price
43/92	P7042	1.00	SPECIAL ORDER	\$4,128.00	\$4,128.00
	P6982	1.00	REPLACEMENT BATTERY 24V	\$229.99	\$229.99
		1.00	LIFT COVER	\$204.99	\$204.99
			Hurry, quote expires 3/14/2015		
Comments:					
This is Pro Pool-XR Lift Part # F-004PLB-XR (WITH ANCHOR)					
Subtotal					\$4,562.98
Tax					Waived
Handling					Waived
Total					\$4,562.98

Thanks again,

Stan Ellison

John Walters

ALL OF YOUR IN THE SWIM SUPPLIES
 All purchases are subject to terms and drilled solar

ELK GROVE PARK DISTRICT

Bill To: Elk Grove Park District
 499 Biesterfield Road
 Elk Grove Village, IL 60007

To (check one): Attn. J. Walters

- Administration Building
 499 Biesterfield Rd
 Elk Grove Village, IL 60007
- Jack A. Claes Pavilion
 1000 Wellington Ave.
 Elk Grove Village, IL 60007
- Al Hattendorf Center
 225 Elk Grove Blvd.
 Elk Grove Village, IL 60007
- Fox Run Golf Links
 333 Plum Grove Rd.
 Elk Grove Village, IL 60007
- Rainbow Falls Waterpark
 200 Rev. Morrison Blvd.
 Elk Grove Village, IL 60007
- Facility Maintenance Warehouse
 140 Lively Blvd.
 Elk Grove Village, IL 60007

Purchase Order No. **56684**

Purchase Order Date 2, 17, 15

Vendor No. _____

Vendor In the Swim

Contact Person Stan Ellison

WHITE COPY: Vendor Copy
 YELLOW COPY: Accounts Payable Copy - attach to back of invoice
 PINK COPY: Purchaser's File Copy

Description	G/L Number	Total
1. RBF- Pool Lift (Leisure Pool)	23-7-0001-740005	\$4562.98
2.		
3.		
4.		

Not less than the prevailing rate of wages as found by the Elk Grove Park District or the Illinois Department of Labor or as determined by the court on review shall be paid by the Contractor/Vendor and all subcontractors to all laborers, workers, and mechanics performing work on the project. If such rates change prior to completion of the work it is the duty of the contractor to pay such revised rates to laborers, workers and mechanics performing work hereunder. The Contractor is required to verify current prevailing wages prior to the first day of each month and to pay the then-current prevailing wage rate. The prevailing wage rates are revised by the Department of Labor (IDOL) and are available on the department's website at www.state.il.us/agency/idol. Further, the contractor shall provide certified payrolls to the Park District as provided by the Illinois Prevailing Wage Act [820 ILCS 30/0.01 et seq.]

John Walters
Stan Ellison
 [Signature]



General Contractors

Schaefges Brothers, Inc. / 851 Seton Court, Suite 2A, Wheeling, Illinois 60090-5790

Tel (847) 537-3330 · Fax (847) 537-7439 · www.sbigc.com

INVOICE

INVOICE NO:1430

To: Elk Grove Park District
499 Biesterfield Road
Elk Grove Village, IL 60007

DATE: April 30, 2015

Attn: John Walters

RE: Rainbow Falls

Project: Lazy River Repairs/Concrete

QUANTITY	DESCRIPTION	AMOUNT
Po# 57610 -	ADA Lift concrete	\$3,690.00
Po# 57630 -	Lazy River repairs	\$3,618.00
	Additional concrete removal and replacement at the pool gutter	\$ 250.00
Total Due		\$7,558.00

Kindly Remit

THANK YOU FOR YOUR BUSINESS!



ELK GROVE PARK DISTRICT

Bill To: Elk Grove Park District
499 Biesterfield Road
Elk Grove Village, IL 60007

Purchase Order No. 57630

Purchase Order Date 4/29/15

Vendor No. _____

Vendor Schaefges Bros. Inc

Contact Person Steve

WHITE COPY: Vendor Copy
YELLOW COPY: Accounts Payable Copy - attach to back of invoice
PINK COPY: Purchaser's File Copy

Ship To (check one): Attn: J. Walters

- Administration Building
499 Biesterfield Rd
Elk Grove Village, IL 60007
- Jack A. Claes Pavilion
1000 Wellington Ave.
Elk Grove Village, IL 60007
- Al Hattendorf Center
225 Elk Grove Blvd.
Elk Grove Village, IL 60007
- Fox Run Golf Links
333 Plum Grove Rd.
Elk Grove Village, IL 60007
- Rainbow Falls Waterpark
200 Rev. Morrison Blvd.
Elk Grove Village, IL 60007
- Facility Maintenance Warehouse
140 Lively Blvd.
Elk Grove Village, IL 60007

Description	G/L Number	Total
1. Lazy River Concrete Repairs	20-5-3310-536385	\$ 3618.00
2. RBF - Concrete Repairs	20-5-3310-530385	\$ 250.00
3.		
4.		
		\$ 3868.00

Not less than the prevailing rate of wages as found by the Elk Grove Park District or the Illinois Department of Labor or as determined by the court on review shall be paid by the Contractor/Vendor and all subcontractors to all laborers, workers, and mechanics performing work on the project. If such rates change prior to completion of the work it is the duty of the contractor to pay such revised rates to laborers, workers and mechanics performing work hereunder. The Contractor is required to verify current prevailing wages prior to the first day of each month and to pay the then-current prevailing wage rate. The prevailing wage rates are revised by the Department of Labor (IDOL) and are available on the department's website at www.state.il.us/agency/idol. Further, the contractor shall provide certified payrolls to the Park District as provided by the Illinois Prevailing Wage Act [820 ILCS 130/0.01 et seq.]

J. Walters
[Signature]

2015 Concrete Projects Bid Tab Results

March 17, 2015

Contractor	PC Pirate Jet Ride	PC Safari Train	Shenandoah	Audubon	Total	Cont. Address
A Lamp Concrete Construction	\$ 3,555.00	\$ 3,520.00	\$ 26,438.00	\$ 57,330.00	\$ 90,843.00	
Continental Construction	\$ 4,398.00	\$ 4,224.00	\$ 19,763.00	\$ 63,223.00	\$ 91,608.00	
E. Hoffman Inc.	\$ 4,932.00	\$ 4,576.00	\$ 22,597.00	\$ 64,330.00	\$ 96,435.00	
G & M Cement Construction	\$ 6,165.00	\$ 5,280.00	\$ 30,305.00	\$ 88,335.00	\$ 162,755.00	
Globe Construction	\$ 12,330.00	\$ 14,080.00	\$ 71,835.00	\$ 105,155.00	\$ 203,400.00	
Submitted by:						
Witnessed by:						



ELK GROVE PARK DISTRICT

Bill To: Elk Grove Park District
499 Biesterfield Road
Elk Grove Village, IL 60007

Purchase Order No. **55448**

Purchase Order Date 8 / 28 / 15

Vendor No. _____

Ship To (check one): Attn. _____

- Administration Building
499 Biesterfield Rd.
Elk Grove Village, IL 60007
- Jack A. Claes Pavilion
1000 Wellington Ave.
Elk Grove Village, IL 60007
- Al Hattendorf Center
225 Elk Grove Blvd.
Elk Grove Village, IL 60007
- Fox Run Golf Links
333 Plum Grove Rd.
Elk Grove Village, IL 60007
- Rainbow Falls Waterpark
200 Rev. Morrison Blvd.
Elk Grove Village, IL 60007
- Facility Maintenance Warehouse
140 Lively Blvd.
Elk Grove Village, IL 60007

Vendor A-Lamp Construction
1400 Wright Blvd
2 Hammondig, IL 60113

Contact Person _____

WHITE COPY: Vendor Copy
YELLOW COPY: Accounts Payable Copy -
attach to back of invoice
PINK COPY: Purchaser's File Copy

Description	G/L Number	Total
1. Audubon Playground work	52-6-0001-600078	2570
2. 10% retained	52-6-0001-600069	909.17
3. 10% retained	52-6-0001-600032	454.59
4. 10% retained	52-6-0001-600003	
Total		26,511.76

Not less than the prevailing rate of wages as found by the Elk Grove Park District or the Illinois Department of Labor or as determined by the court on review shall be paid by the Contractor/Vendor and all subcontractors to all laborers, workers, and mechanics performing work on the project. If such rates change prior to completion of the work it is the duty of the contractor to pay such revised rates to laborers, workers and mechanics performing work hereunder. The Contractor is required to verify current prevailing wages prior to the first day of each month and to pay the then-current prevailing wage rate. The prevailing wage rates are revised by the Department of Labor (IDOL) and are available on the department's website at www.state.il.us/agency/idol. Further, the contractor shall provide certified payrolls to the Park District as provided by the Illinois Prevailing Wage Act [820 ILCS 130/0.01 et seq.]

A LAMP CONCRETE CONTRACTORS, INC.
 1900 WRIGHT BOULEVARD
 SCHAUMBURG, IL 60193
 PHONE (847) 891-6000 FAX (847) 891-6100

Pay Application #	Date	Terms	Contract Date	Purchase Order #
3 - FINAL	08/04/15	UPON RECEIPT	03/31/15	N/A

CUSTOMER NUMBER 8598
 ELK GROVE PARK DISTRICT
 499 BIESTERFIELD ROAD
 ELK GROVE VILLAGE, IL 60007
 PHONE (847) 437-9494 FAX (847) 228-3508

JOB #: 15018

PROJECT NAME: Elk Grove Park District - 2015 Concrete Projects @ Various Parks
Pirates Cove Theme Park - Shenandoah Park - Audubon Skate Park
 CONTRACT AMOUNT: \$ 61,923.60
 CURRENT PAYMENT: \$ 26,519.76

INVOICE # 15105

PERIOD FROM:	06/05/15	PERIOD TO:	08/04/15
--------------	----------	------------	----------

PH CODE	BID ITEM	ITEM DESCRIPTION	UOM	PLAN QTY	UNIT COST	TOTAL	PREVIOUS QUANTITY	PREVIOUS AMOUNT	CURRENT QUANTITY	CURRENT AMOUNT	TO DATE QUANTITY	TO DATE AMOUNT
9001	1	12x12 PAD W/AGG BASE (5 IN)	SF	144.00	\$ 8.00	\$1,152.00	144	\$ 1,152.00	0	\$ 0	144	\$ 1,152.00
9002	2	CONTROL STA CONC PAD	SF	267.00	\$ 9.00	\$2,403.00	267	\$ 2,403.00	0	\$ 0	267	\$ 2,403.00
9003	3	PC SAFARI TRAIN TRACK BASE	SF	352.00	\$ 10.00	\$3,520.00	352	\$ 3,520.00	0	\$ 0	352	\$ 3,520.00
9004	4	Project #2 - SHENANDOAH PARK @ Meacham Rd. & Haar Ln. SHELTER FOOTINGS 24X48 DEEP	EA	4.00	\$ 2,000.00	\$8,000.00	4	\$ 8,000.00	0	\$ 0	4	\$ 8,000.00
9005	5	5 IN PCC WALK & 4 IN BASE & CONC SHELTER PAD	SF	707.00	\$ 9.00	\$6,363.00	465	\$ 4,185.00	242	\$ 2,178.00	707	\$ 6,363.00
9006	6	5 FT WIDE PCC WALK & CURB COMB	LF	60.00	\$ 40.00	\$2,400.00	96	\$ 3,840.00	-36	\$ (1,440.00)	60	\$ 2,400.00
9007	7	6x12 PLAYGRND CURB (INCL RESTOR & SEED)	LF	215.00	\$ 45.00	\$9,675.00	215	\$ 9,675.00	0	\$ 0	215	\$ 9,675.00
9008	8	Project #3 - AUDUBON SKATE PARK @ 300 E. Elk Grove Boulevard REM OF EXST ASPHALT & CONC WALKS & DEBRIS	SF	-	\$ 2.50	\$0.00	0	\$ 0	0	\$ 0	0	\$ 0
9009	9	5 IN PCC WALK & BASE (10 FT WIDE)	SF	-	\$ 7.00	\$0.00	0	\$ 0	0	\$ 0	0	\$ 0
9010	10	INSTALL 6X12 CURB	LF	226.00	\$ 45.00	\$10,170.00	0	\$ 0	226	\$ 10,170.00	226	\$ 10,170.00
9011	11	5 FT WIDE PCC WALK & CURB COMB	LF	120.00	\$ 40.00	\$4,800.00	0	\$ 0	120	\$ 4,800.00	120	\$ 4,800.00
9012	12	5 IN PCC WALK & BASE (5 FT WIDE) (INCL RESTOR & SEED)	SF	875.00	\$ 9.00	\$7,875.00	0	\$ 0	875	\$ 7,875.00	875	\$ 7,875.00
9013	13	UNIT PRICES DEPRESSED CURB (VIL SPEC) 2x4 DET WARN GRAY - VILLAGE STD	LF	-	\$ 50.00	\$0.00	0	\$ 0	0	\$ 0	0	\$ 0
9014	14	RESTORATION SOD IN LIEU OF SEED	SF	-	\$ 15.00	\$0.00	0	\$ 0	0	\$ 0	0	\$ 0
9015	15	5 IN CONC WALK W/REINFORCEMENT	SF	-	\$ 8.00	\$0.00	0	\$ 0	0	\$ 0	0	\$ 0
9016	16	4 IN COMPACT CA-6 AGG BASE	SF	-	\$ 1.00	\$0.00	0	\$ 0	0	\$ 0	0	\$ 0
9017	17	EXC & REM (MEASURE PRIOR TO REMOVAL)	SY	-	\$ 15.00	\$0.00	0	\$ 0	0	\$ 0	0	\$ 0
						TOTAL - BASE BID \$	\$	32,775.00	\$	23,663.00	\$	56,358.00

A LAMP CONCRETE CONTRACTORS, INC.
 1900 WRIGHT BOULEVARD
 SCHAUMBURG, IL 60193
 PHONE (847) 891-6000 FAX (847) 891-6100

Pay Application #	Date	Terms	Contract Date	Purchase Order #
3 - FINAL	08/04/15	UPON RECEIPT	03/31/15	N/A

JOB #: 15018
PROJECT NAME: Elk Grove Park District - 2015 Concrete Projects @ Various Parks
Pirates Cove Theme Park - Shenandoah Park - Audubon Skate Park
CONTRACT AMOUNT: \$ 61,923.60
CURRENT PAYMENT: \$ 26,519.76

PERIOD FROM: 06/05/15 **PERIOD TO:** 08/04/15

PH CODE	BID ITEM	ITEM DESCRIPTION	UOM	PLAN QTY	UNIT COST	TOTAL	PREVIOUS QUANTITY	PREVIOUS AMOUNT	CURRENT QUANTITY	CURRENT AMOUNT	TO DATE QUANTITY	TO DATE AMOUNT
---------	----------	------------------	-----	----------	-----------	-------	-------------------	-----------------	------------------	----------------	------------------	----------------

UNIT PRICING EXTRA TO BASE BID												
Project #1 - PIRATES COVE THEME PARK @ 901 Leicester Road												
8201	CO #1	Item #9001 - Under Plan Qty	SF	44.00	(\$8.00)	(\$352.00)	44	\$	0	\$	44	\$
8202	CO #1	Item #9002 - Over Plan Qty	SF	92.00	\$9.00	\$828.00	92	\$	0	\$	92	\$
8203	CO #2	Item #9003 - Over Plan Qty	SF	87.00	\$10.00	\$870.00	87	\$	0	\$	87	\$
8204	CO #2	Item #9002 - Over Plan Qty	SF	70.00	\$9.00	\$630.00	70	\$	0	\$	70	\$
8205	CO #2	Item #9003 - Over Plan Qty	SF	350.00	\$10.00	\$3,500.00	350	\$	0	\$	350	\$
8206	CO #2	Item #9017 - Additional Excavation	SY	52.44	\$15.00	\$786.60	52.44	\$	0	\$	52.44	\$
8207	CO #2	AUP - Additional Concrete Ride Pad 8"	CY	1.00	\$300.00	\$300.00	1	\$	0	\$	1	\$
8208	CO #3	Item #9005 - Under Plan Qty	SF	242.00	(\$9.00)	(\$2,178.00)	241	\$	241	(\$2,169.00)	242	\$
8209	CO #3	Item #9006 - Over Plan Qty	LF	36.00	\$40.00	\$1,440.00	1	\$	35	\$	36	\$
8210	CO #3	Item #9011 - Under Plan Qty	LF	13.00	(\$40.00)	(\$520.00)	1	\$	12	\$	13	\$
8211	CO #3	Item #9012 - Over Plan Qty	SF	29.00	\$9.00	\$261.00	1	\$	28	\$	29	\$
TOTAL - EXTRAS \$						5,565.60		\$	(997.00)	\$		5,565.60

TOTAL CONTRACT (BASE BID + EXTRAS) \$ 61,923.60
\$ 39,337.60
\$ 22,586.00
\$ 61,923.60

BILLING SUMMARY FOR JOB

	CURRENT	TO DATE
Complete to Date	\$ 22,586.00	\$ 61,923.60
Other Deduction	\$ -	\$ -
Less Retainage @ %	0.00 \$ 3,933.76	\$ -
Balance	\$ 26,519.76	\$ 61,923.60
Less Previous Payments	\$ -	\$ (35,403.84)
Total Amount Due	\$ 26,519.76	\$ 26,519.76

Created 3/21/15



ELK GROVE PARK DISTRICT

Bill To: Elk Grove Park District
499 Biesterfield Road
Elk Grove Village, IL 60007

Purchase Order No. **55424**

Purchase Order Date **3 / 27 / 15**

Ship To (check one): Attn. Valerie Lomme

- Administration Building
499 Biesterfield Rd
Elk Grove Village, IL 60007
- Jack A. Claes Pavilion
1000 Wellington Ave.
Elk Grove Village, IL 60007
- Al Hattendorf Center
225 Elk Grove Blvd.
Elk Grove Village, IL 60007

- Fox Run Golf Links
333 Plum Grove Rd.
Elk Grove Village, IL 60007
- Rainbow Falls Waterpark
200 Rev. Morrison Blvd.
Elk Grove Village, IL 60007
- Facility Maintenance Warehouse
140 Lively Blvd.
Elk Grove Village, IL 60007

Vendor No.

Landscaping Structures
601 7th St. South
Delano, MN 55328

Contact Person Jennifer Miller

WHITE COPY: Vendor Copy
YELLOW COPY: Accounts Payable Copy -
attach to back of invoice
PINK COPY: Purchaser's File Copy

Description	G/L Number	Total
1. Zip 61602's Little Swing	23-7-0001-740005	9,000
2. Zip 210A Swing	52-6-0001-600078	23,378
3. Proposed 3/20/15 Road		
4. Ardubunk 30 E. Elk Grove Blvd		(32,378)

Not less than the prevailing rate of wages as found by the Elk Grove Park District or the Illinois Department of Labor or as determined by the court on review shall be paid by the Contractor/Vendor and all subcontractors to all laborers, workers, and mechanics performing work on the project. If such rates change prior to completion of the work it is the duty of the contractor to pay such revised rates to laborers, workers and mechanics performing work hereunder. The Contractor is required to verify current prevailing wages prior to the first day of each month and to pay the then-current prevailing wage rate. The prevailing wage rates are revised by the Department of Labor (IDOL) and are available on the department's website at www.state.il.us/agency/idol. Further, the contractor shall provide certified payrolls to the Park District as provided by the Illinois Prevailing Wage Act [820 ILCS 130/0.01 et seq.]

Valerie Lomme

Approved at 03/17/15 3:26/15

INV# 015558

Volume 11/2/15



Invoice INV-015558

Page 1 of 2

Bill To: C083994

Ship To: C083994

Elk Grove Park District
499 Biesterfield Rd
Elk Grove Village IL 60007
USA

Elk Grove Park District
Facilities Maintenance Warehouse
140 Lively Blvd
Elk Grove Village IL 60007
USA

Project ID P0019808-01
Dealer 101 NuToys Leisure Products, Inc.
Requested Ship Date 04/22/2015
Ship Via
Freight Terms 3rd Party Bill

Customer Order 55424
Invoice Date 04/22/2015
Payment Terms Net 30 Days
Cash Discount Terms
Project Name Audubon Park

Order Comments Call Prior - 24 hours prior to Valerie @ 847-942-1688

Line	P & M Code	Item #	Description	Product Line	Quantity	Unit of Measure
1.0	A	111783	INDEP PLAY COMPONENTS	52	1.00	EA
			INDEP PLAY COMPONENTS			
2.0	A	177334	Single Post Swing Frame Anti-Wrap Ha...	52	1.00	EA
			Description: Single Post Swing Frame Anti-Wrap Hangers 8' Beam Height Only, Posts: 319 Tangerine, Clamps: 319 Tangerine, Independent Items: 007 Yellow			
3.0	A	177335	Single Post Swing Frame Additional B...	52	1.00	EA
			Description: Single Post Swing Frame Additional Bay Anti-Wrap Hangers 8' Beam Height Only, Posts: 319 Tangerine, Independent Items: 007 Yellow			
4.0	A	174018	Belt Seat w/2 Chains	52	4.00	EA
			Description: Belt Seat ProGuard Chains for 8' Beam Height			
5.0	A	177334	Single Post Swing Frame Anti-Wrap Ha...	52	1.00	EA
			Description: Single Post Swing Frame Anti-Wrap Hangers 8' Beam Height Only, Posts: 319 Tangerine, Clamps: 319 Tangerine, Independent Items: 007 Yellow			
6.0	A	177335	Single Post Swing Frame Additional B...	52	1.00	EA
			Description: Single Post Swing Frame Additional Bay Anti-Wrap Hangers 8' Beam Height Only, Posts: 319 Tangerine, Independent Items: 007 Yellow			
7.0	A	176038	Full Bucket Seat w/2 Chains	52	2.00	EA
			Description: Full Bucket Seat ProGuard Chains for 8' Beam Height			
8.0	A	177351	Molded Bucket Seat w/Harness and w/C...	52	2.00	EA
			Description: Molded Bucket Seat w/Harness ProGuard Chains for 8' Beam Height, Molded Bucket Seats: 044 Tan, Seat Harness: 319 Tangerine			
9.0	A	173592	Oodle Swing	52	1.00	EA
			Description: DB Only, Independent Items: 319 Tangerine, Molded Bucket Seats: 317 Limon			

Continued on next page

601 7th St. South, Delano, MN 55328 • Tel 763.972.5200 • 888.438.6574 • Fax 763.972.3185 • playlsi.com



ELK GROVE PARK DISTRICT

Bill To: Elk Grove Park District
499 Biesterfield Road
Elk Grove Village, IL 60007

Purchase Order No. **55422**

Purchase Order Date 3 / 27 / 15

Vendor No. _____

Vendor Cunningham Recreation
GameHome

Ship To (check one): Attn. Valerie Lemme

- Administration Building
499 Biesterfield Rd
Elk Grove Village, IL 60007
- Jack A. Claes Pavilion
1000 Wellington Ave.
Elk Grove Village, IL 60007
- Al Hattendorf Center
225 Elk Grove Blvd.
Elk Grove Village, IL 60007

- Fox Run Golf Links
333 Plum Grove Rd.
Elk Grove Village, IL 60007
- Rainbow Falls Waterpark
200 Rev. Morrison Blvd.
Elk Grove Village, IL 60007
- Facility Maintenance Warehouse
140 Lively Blvd.
Elk Grove Village, IL 60007

Contact Person Bill Patterson

WHITE COPY: Vendor Copy
YELLOW COPY: Accounts Payable Copy -
attach to back of invoice
PINK COPY: Purchaser's File Copy

Description	G/L Number	Total
1. <u>Crosshopper Ridge Lake Item</u>	<u>52-6-0001-600078</u>	<u>\$123,466.30</u>
2.	<u>23-7-0001-740005</u>	<u>9,000.00</u>
3.		
4.		

Not less than the prevailing rate of wages as found by the Elk Grove Park District or the Illinois Department of Labor or as determined by the court on review shall be paid by the Contractor/Vendor and all subcontractors to all laborers, workers, and mechanics performing work on the project. If such rates change prior to completion of the work it is the duty of the contractor to pay such revised rates to laborers, workers and mechanics performing work hereunder. The Contractor is required to verify current prevailing wages prior to the first day of each month and to pay the then-current prevailing wage rate. The prevailing wage rates are revised by the Department of Labor (IDOL) and are available on the department's website at www.state.il.us/agency/idol. Further, the contractor shall provide certified payrolls to the Park District as provided by the Illinois Prevailing Wage Act [820 ILCS 130/0.01 et seq.]

Approved at B/11/19 3/26/15

Valerie Lemme

[Signature]

Cunningham Associates, Inc.
 PO Box 240981
 Charlotte, NC 28224
 Phone Number: 704-525-5174 • Fax Number: 704-525-7356

Invoice
 Invoice Number: 2269
 Invoice Date: 3/31/2015

Elk Grove Park District - Early Bird Sale Proposal

Bill To:
 Elk Grove Park District
 Attn: Valerie Lemme
 499 Biesterfield Road
 Elk Grove Village, IL 60007
 Phone: 847-228-3513
 vlemme@elkgroveparks.org

Ship To
 Elk Grove Park District
 Attn: Joe Palmisano
 140 Lively Blvd
 Elk Grove Village, IL 60007
 Phone: 847-708-8161
 Fax: 847-228-3488

Customer PO	Payment Terms	Sales Rep	Due Date
55422		Bill Patterson	4/30/2015

Stock ID	Description	Quantity	Unit Price	Amount
178749	Owner's Kit	1	\$50.00	\$50.00
RDU	19562 - PrimeTime Grasshopper Ridge	1	\$29,641.00	\$29,641.00

Contract: Standard Pricing

Please remit payment to:

Cunningham Associates, Inc.
 PO Box 240981
 Charlotte, NC 28224
 Phone Number: 704-525-5174 • Fax Number: 704-525-7356

SubTotal: \$29,691.00
 Discount: \$10,371.89
 Estimated Freight: \$2,147.19
 Total Invoice Amount: \$21,466.30
 Payment Received: \$0.00
Total Due: \$21,466.30

23-7-0001-740005
 GL# 52-6-0001-600078
 Description Audubon Playground Renovation

MAR 31 2015

Approval V. Lemme
 P.O. # 55422

Paid on T.B.P-Card



AUDUBON PARK 300 E. ELK GROVE BLV. 2-5yr old Composite





AUDUBON ZIP-KRUZ PARALLEL PLAY - ADAPTIVE SEAT + GROUP SWING



E. Hoffman Inc

21W448 North Avenue
Lombard, IL 60148

email: ed@ehoffmaninc.com

Phone: 630-495-3526

Fax: 630-495-3527

Invoice

Date	Invoice #
11/18/2015	28204

Bill To
Elk Grove Park District 499 Biesterfield Road Elk Grove Village, IL 60007

Job Name
Mead Park 1670 Biesterfield Elk Grove Village, IL 60007

Terms	P.O. No.
	59667

Date	Description	Lds/Hrs	Rate	Amount
	Construction Draw Out-of-state sale, exempt from sales tax		7,600.00 0.00%	7,600.00 0.00
<p>SI # 23-7-0001-740005 Description MEAD CONC. WALK REPAIR NOV 22 2015 Approval <i>[Signature]</i> P.O. # 59667</p>				
Thank you for your business.			Total	\$7,600.00



ELK GROVE PARK DISTRICT

Bill To: Elk Grove Park District
499 Biesterfield Road
Elk Grove Village, IL 60007

Purchase Order No. 59667

Purchase Order Date 10 / 30 / 15

Vendor No. _____

Ship To (check one): Attn. Valerie Lemme

Vendor E. Hoffman, Inc
21 W 448 North Ave
Hoffman Ests Lombard, IL 60141
630-495-3526

Contact Person Ed 630-337-8909

WHITE COPY: Vendor Copy
YELLOW COPY: Accounts Payable Copy -
attach to back of invoice
PINK COPY: Purchaser's File Copy

- Administration Building
499 Biesterfield Rd
Elk Grove Village, IL 60007
- Jack A. Claes Pavilion
1000 Wellington Ave.
Elk Grove Village, IL 60007
- Al Hattendorf Center
225 Elk Grove Blvd.
Elk Grove Village, IL 60007
- Fox Run Golf Links
333 Plum Grove Rd.
Elk Grove Village, IL 60007
- Rainbow Falls Waterpark
200 Rev. Morrison Blvd.
Elk Grove Village, IL 60007
- Facility Maintenance Warehouse
140 Lively Blvd.
Elk Grove Village, IL 60007

Description	G/L Number	Total
1. MEAD CONC - ADA	23-7-0001-740005	7,600
2. remove & replace for trip hazards		
3.		
4.		

Not less than the prevailing rate of wages as found by the Elk Grove Park District or the Illinois Department of Labor or as determined by the court on review shall be paid by the Contractor/Vendor and all subcontractors to all laborers, workers, and mechanics performing work on the project. If such rates change prior to completion of the work it is the duty of the contractor to pay such revised rates to laborers, workers and mechanics performing work hereunder. The Contractor is required to verify current prevailing wages prior to the first day of each month and to pay the then-current prevailing wage rate. The prevailing wage rates are revised by the Department of Labor (IDOL) and are available on the department's website at www.state.il.us/agency/idol. Further, the contractor shall provide certified payrolls to the Park District as provided by the Illinois Prevailing Wage Act [820 ILCS 130/0.01 et seq.]

Valerie Lemme
[Signature]

INV DATE - 11-19-15 # 28204

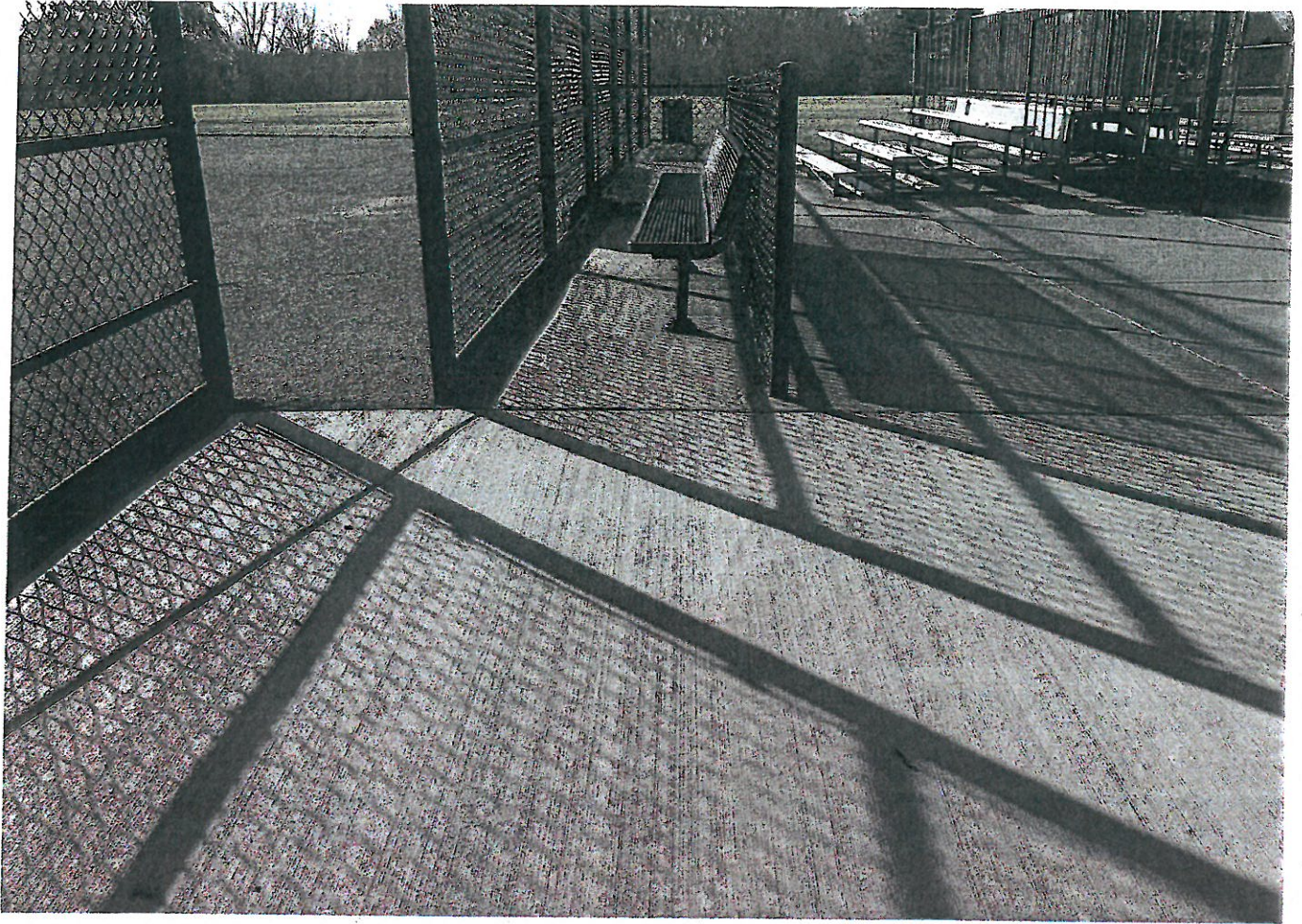

MEAD BALL FIELDS - REPLACEMENT CONCRETE - ACCESSIBLE ROUTE



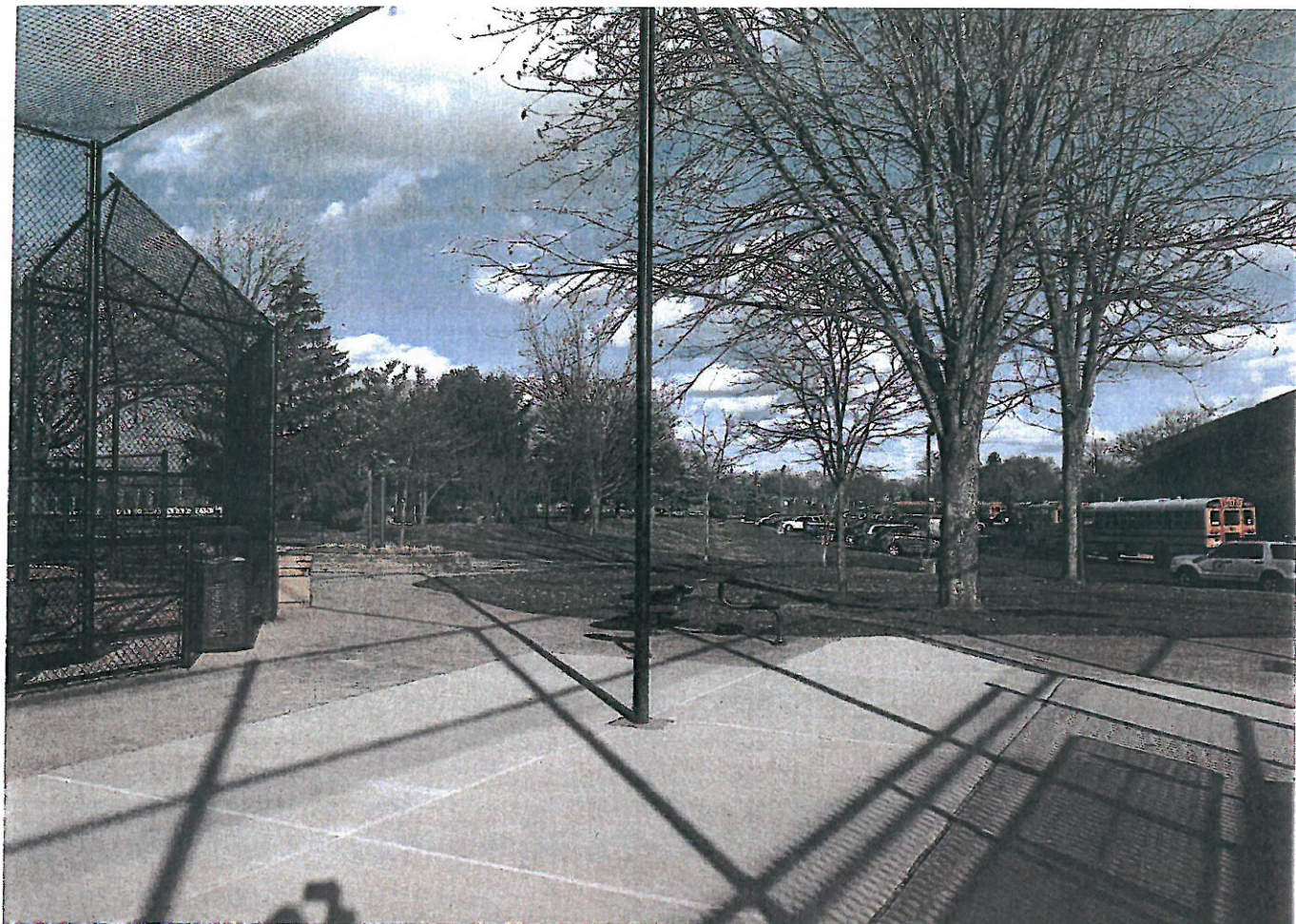

MEAD ACCESSIBLE ROUTE & SPECTATOR AREA - ADA PICNIC TABLE



E. Hoffman Inc

21W448 North Avenue
 Lombard, IL 60148
 email: ed@ehoffmaninc.com
 Phone: 630-495-3526
 Fax: 630-495-3527

Invoice

Date	Invoice #
11/18/2015	28203

Bill To
Elk Grove Park District 499 Biesterfield Road Elk Grove Village, IL 60007

Job Name
Elk Grove Village, IL 60007 <i>Johnson ADA Fishing Pier</i> <i>974 DAVID LANE</i>

Terms	P.O. No.
	59668

Date	Description	Lds/Hrs	Rate	Amount
	Construction Draw - <i>conc.</i> Out-of-state sale, exempt from sales tax		11,660.00 0.00%	11,660.00 0.00

OL# 23-7-0001-740005
Description Johnson ADA Conc. Pier
3 Walk for Fishing Pier
NOV 23 2015
Approval V. J. Henne
P.O. # 59668

Thank you for your business.	Total	\$11,660.00
------------------------------	--------------	-------------



ELK GROVE PARK DISTRICT

Bill To: Elk Grove Park District
499 Biesterfield Road
Elk Grove Village, IL 60007

Purchase Order No. **59668**

Purchase Order Date 10 / 30 / 15

Vendor No. _____

Ship To (check one): Attn. Valerie Henne

Vendor E. Hoffman, Inc
21 W 448 North Ave
Lombard, IL 60148
630-495-3526

Contact Person Ed 630-337-8909

- Administration Building
499 Biesterfield Rd
Elk Grove Village, IL 60007
- Jack A. Claes Pavilion
1000 Wellington Ave.
Elk Grove Village, IL 60007
- Al Hattendorf Center
225 Elk Grove Blvd.
Elk Grove Village, IL 60007

- Fox Run Golf Links
333 Plum Grove Rd.
Elk Grove Village, IL 60007
- Rainbow Falls Waterpark
200 Rev. Morrison Blvd.
Elk Grove Village, IL 60007
- Facility Maintenance Warehouse
140 Lively Blvd.
Elk Grove Village, IL 60007

WHITE COPY: Vendor Copy
YELLOW COPY: Accounts Payable Copy - attach to back of invoice
PINK COPY: Purchaser's File Copy

Description	G/L Number	Total
1. <u>Johnson Pond Conc^{rt} Pier's Walk</u>	<u>23-7-0001-740005</u>	<u>11,660</u>
2.		
3.		
4.		

Not less than the prevailing rate of wages as found by the Elk Grove Park District or the Illinois Department of Labor or as determined by the court on review shall be paid by the Contractor/Vendor and all subcontractors to all laborers, workers, and mechanics performing work on the project. If such rates change prior to completion of the work it is the duty of the contractor to pay such revised rates to laborers, workers and mechanics performing work hereunder. The Contractor is required to verify current prevailing wages prior to the first day of each month and to pay the then-current prevailing wage rate. The prevailing wage rates are revised by the Department of Labor (IDOL) and are available on the department's website at www.state.il.us/agency/idol. Further, the contractor shall provide certified payrolls to the Park District as provided by the Illinois Prevailing Wage Act [820 ILCS 130/0.01 et seq.]

Valerie Henne
[Signature]

INV DATE 11-18-15 INV # 28203



Johnson Fishing Pier - Accessible Route & Concrete Abutment for Fishing Pier





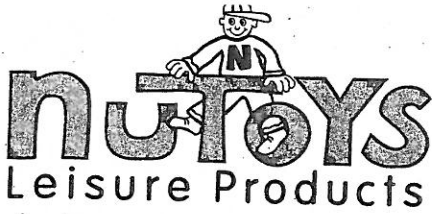

Invoice

DATE	INVOICE #
10/26/2015	43656

P.O. BOX 2121 LAGRANGE, IL. 60525

BILL TO
Elk Grove Park District 499 Biesterfield Rd. Elk Grove Village, IL 60007 attn: Accts Payable

SHIP TO
SAME

CONTACT NAME	CONTACT PHONE
	847.878.4855

P.O. NO.	TERMS	REP	PROJECT TITLE	PROJECT CITY
59663	Net 30	RB	Lindberg School	Elk Grove Village

ITEM	QTY	DESCRIPTION	RATE	AMOUNT
Misc.	2	Molded Bucket Seat w/ Harness & Proguard Chains	655.00	1,310.00
Shipping		Shipping Costs	136.00	136.00

It's Just More Fun! Thank you for your order!

Total \$1,446.00

GL# 23-7-0001-740005
Description ADA swing seats
Lindbergh

NOV 08 2015

Approval [Signature]
P.O. # 59663



ELK GROVE PARK DISTRICT

Bill To: Elk Grove Park District
499 Biesterfield Road
Elk Grove Village, IL 60007

Purchase Order No. **59663**

Purchase Order Date 10/1/15

Vendor No. _____

Ship To (check one): Attn. Wenne Lemme

- Administration Building
499 Biesterfield Rd.
Elk Grove Village, IL 60007
- Jack A. Claes Pavilion
1000 Wellington Ave.
Elk Grove Village, IL 60007
- Al Hattendorf Center
225 Elk Grove Blvd.
Elk Grove Village, IL 60007

- Fox Run Golf Links
333 Plum Grove Rd.
Elk Grove Village, IL 60007
- Rainbow Falls Waterpark
200 Rev. Morrison Blvd.
Elk Grove Village, IL 60007
- Facility Maintenance Warehouse
140 Lively Blvd.
Elk Grove Village, IL 60007

Vendor Nv-Tony Leisner Products
P.O. Box 2121
Ludwigs, IL 60525

Contact Person Leisner Rivera

WHITE COPY: Vendor Copy
YELLOW COPY: Accounts Payable Copy -
attach to back of invoice
PINK COPY: Purchaser's File Copy

Description	G/L Number	Total
1. 2-17735 10 molded bucket seats	23-7-0001-740005	1446.00
2. 8' beam, uncoated chain		
3. Color granite		
4. Ship JIBS		

Not less than the prevailing rate of wages as found by the Elk Grove Park District or the Illinois Department of Labor or as determined by the court on review shall be paid by the Contractor/Vendor and all subcontractors to all laborers, workers, and mechanics performing work on the project. If such rates change prior to completion of the work it is the duty of the contractor to pay such revised rates to laborers, workers and mechanics performing work hereunder. The Contractor is required to verify current prevailing wages prior to the first day of each month and to pay the then-current prevailing wage rate. The prevailing wage rates are revised by the Department of Labor (IDOL) and are available on the department's website at www.state.il.us/agency/idol. Further, the contractor shall provide certified payrolls to the Park District as provided by the Illinois Prevailing Wage Act [820 ILCS 130/0.01 et seq.]

Valmiggia Perdue



FOX RUN GOLF CLUB - NEW PARKING SIGNS





Divine Signs and Graphics

601 Estes Avenue
Schaumburg, IL 60193
Ph: (847) 534-9220
FAX: (847) 534-9221
Email: jmill@divinesignsinc.com
Web: http://www.DivineSignsInc.com

Invoice #: 20063

Order Created: 9/28/2015 9:21:54AM
Sale Date: 9/30/2015 2:32:19PM
Payment Due: **10/30/2015**
PO #: 59660

Sale Date: 9/30/2015 2:32:19PM

Billed To: Elk Grove Park District
Contact: Valerie Gerdes Lemme, Planner II
Address: 499 Biesterfeld Road
Elk Grove Village, IL 60007

Email: vlemme@elkgroveparks.org
Office Phone: (847) 228-3513
Office Fax: (847) 228-3508

Created Date: 9/28/2015 9:21:54AM
Salesperson: Mike Miller
Email: mike@divinesignsinc.com
Office Phone: (847) 534-9220
Office Fax: (847) 534-9221

Description: Handicap & No Parking Signs

		Quantity	Unit Price	Subtotal
1	Product: Misc Description: 12" x 18" Reflective .080 Aluminum Handicap Parking Signs. <i>Fox Run</i>	4.00	\$22.40	\$89.60
2	Product: Misc Description: 12" x 18" Reflective .080 Aluminum No Parking Any Time <--> Signs. <i>St Julian</i>	3.00	\$23.58	\$70.74

10-5-1013-520270
GL# 23-7-0001-740005
Description *Fox Run ADA / St Julian signs for replacement*

OCT 01 2015

Approval *V. Lemme*
P.O. # *59660*

Order Subtotal: \$160.34
Total Taxes: \$0.00
Total: \$160.34
Order Balance: ~~\$160.34~~

Payment Terms: All Payments are due at our offices within 30 days of order completion or additional interest of 1.5% per month will be assessed.

x _____
If paying by credit card: (Cardholder's Signature). Date
I agree to pay the above total amount according to the card issuer agreement.



ELK GROVE PARK DISTRICT

Bill To: Elk Grove Park District
499 Biesterfield Road
Elk Grove Village, IL 60007

Purchase Order No. **59660**

Purchase Order Date 9/24/18

Vendor No. _____

Ship To (check one): Attn. Valerie Lemme

Vendor Divine Signs
601 Estes Ave
Shumburg IL 60193

Contact Person Brett 847-534-4220

WHITE COPY: Vendor Copy
YELLOW COPY: Accounts Payable Copy -
attach to back of invoice
PINK COPY: Purchaser's File Copy

- Administration Building
499 Biesterfield Rd
Elk Grove Village, IL 60007
- Jack A. Claes Pavilion
1000 Wellington Ave.
Elk Grove Village, IL 60007
- Al Hattendorf Center
225 Elk Grove Blvd.
Elk Grove Village, IL 60007
- Fox Run Golf Links
333 Plum Grove Rd.
Elk Grove Village, IL 60007
- Rainbow Falls Waterpark
200 Rev. Morrison Blvd.
Elk Grove Village, IL 60007
- Facility Maintenance Warehouse
140 Lively Blvd.
Elk Grove Village, IL 60007

Description	G/L Number	Total
1. ADA Parking signs - Fox Run	23 7-0001-740005	89.60
2. No Parking signs - St Julian	10-5-1013-520270	70.74
3.		
4.		

Not less than the prevailing rate of wages as found by the Elk Grove Park District or the Illinois Department of Labor or as determined by the court on review shall be paid by the Contractor/Vendor and all subcontractors to all laborers, workers, and mechanics performing work on the project. If such rates change prior to completion of the work it is the duty of the contractor to pay such revised rates to laborers, workers and mechanics performing work hereunder. The Contractor is required to verify current prevailing wages prior to the first day of each month and to pay the then-current prevailing wage rate. The prevailing wage rates are revised by the Department of Labor (IDOL) and are available on the department's website at www.state.il.us/agency/idol. Further, the contractor shall provide certified payrolls to the Park District as provided by the Illinois Prevailing Wage Act [820 ILCS 130/0.01 et seq.]

Valerie Lemme